

## GROUP S STEP UNITS

These feature rounded leading edges which avoid chipping in normal use.

### S.1 Header nosing

Associated paver accessories: S.2, S.3, S.4

Quantity required: ~ 8.9 No./m

TYPE	A	B	C	R
S.1	215	103	65	25

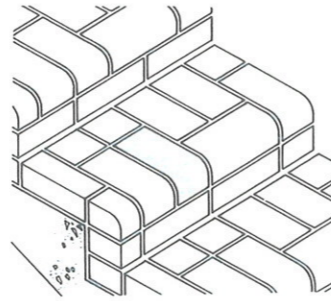
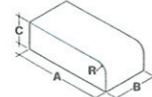
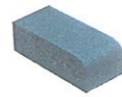

### S.2 Stretcher nosing

Associated paver accessories: S.1, S.3, S.4

Quantity required: ~ 4.4 No./m

TYPE	A	B	C	R
S.2	103	215	65	25

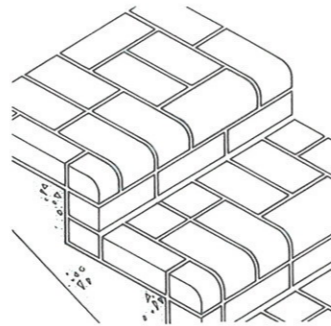
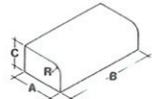

### S.3 Corner nosing (left and right hand)

Associated paver accessories: S.1, S.2, S.4

TYPE	A	B	C	R
S.3	215	103	65	25

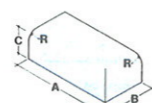
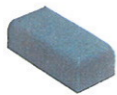

(Right hand)

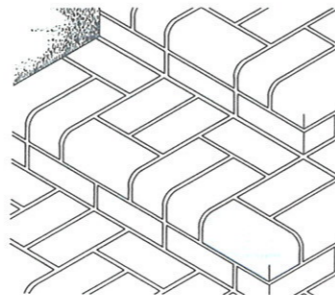

### S.4 Riser/tread make-up

Associated paver accessories: S.1, S.2, S.3

TYPE	A	B	C
S.4	215	103	65

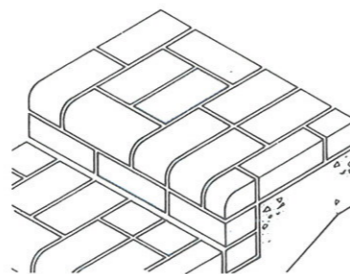
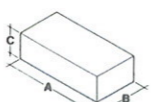
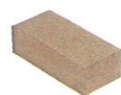

NOTE: Faced on 2 headers, 1 stretcher, 1 bed.

## GROUP D DETERRENT PAVERS

Typically incorporated to deter/prevent use by pedestrians, bicycles, supermarket trollies etc. or vehicle over-run. Generally laid with alternating rows of deterrent units and standard pavers. A choice of units is available offering various degrees of deterrence. In the interests of user safety, careful consideration should be given to the design and location of deterrent features.

### D.1 Slip-top deterrent

TYPE	A	B	C	R
D.1	200	103	150	51

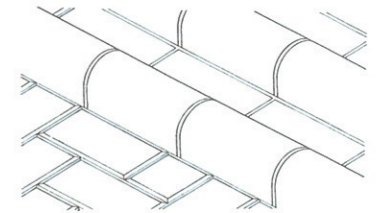
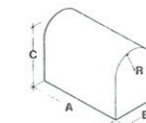
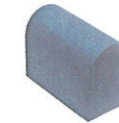

### D.2 Sharp-top deterrent

TYPE	A	B	C	D	E	$\alpha$
D.2	200	103	114	83	150	45°

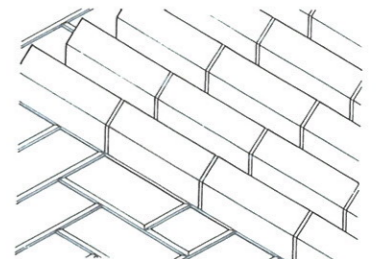
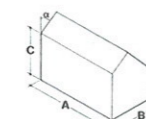

### D.3 Header ridged deterrent

TYPE	A	B	C	D	E	F
D.3	200	100	65	25	50	25

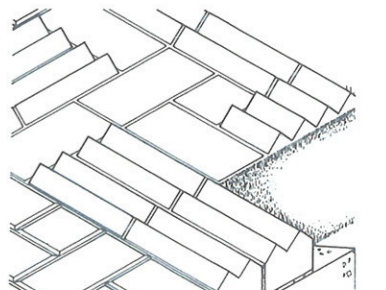
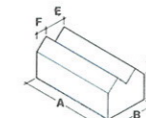

### D.4 Stretcher ridged deterrent

TYPE	A	B	C	D	E	F
D.4	200	100	65	25	50	25

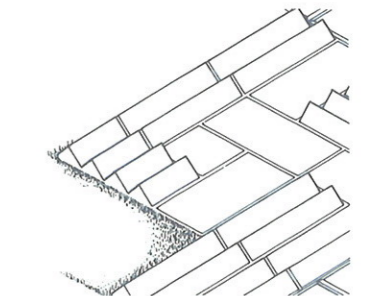
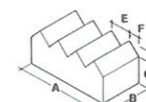

**GROUP BN BULLNOSE BRICKS**

**BN.6 (2.3.6)** Single bullnose stretcher on flat



TYPE	A	B	C	R
BN.6.1	215	103	65	25
BN.6.2	215	103	65	51

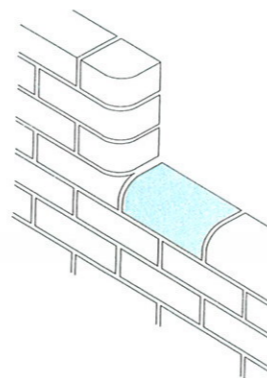
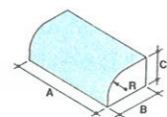

**BN.7 (2.3.7)** Single bullnose internal return, stretcher fair-faced (left and right hand)  
Associated special bricks: BN.1 (2.3.1), BN.5 (2.3.5), BN.6 (2.3.6)



TYPE	A	B	C	R
BN.7.1	215	103	65	25
BN.7.2	215	103	65	51

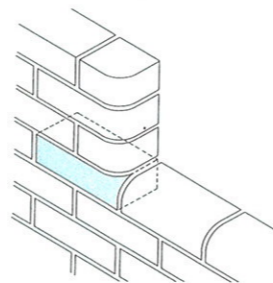
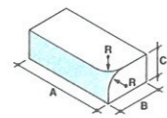

**BN.8 (2.3.8)** Single bullnose internal return, header fair-faced (left and right hand)  
Associated special bricks: BN.1 (2.3.1), BN.5 (2.3.5), BN.6 (2.3.6)



TYPE	A	B	C	R
BN.8.1	215	103	65	25
BN.8.2	215	103	65	51

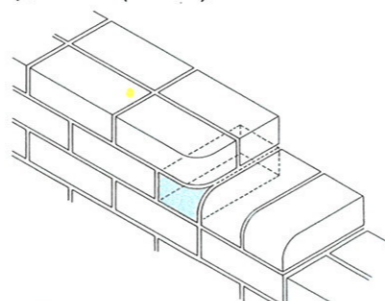
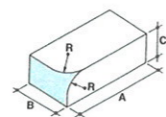

**BN.9 (2.3.9)** Bullnose internal return, flat fair-faced (left and right hand)  
Associated special bricks: BN.5 (2.3.5), BN.6 (2.3.6)



TYPE	A	B	C	R
BN.9.1	215	103	65	25
BN.9.2	215	103	65	51

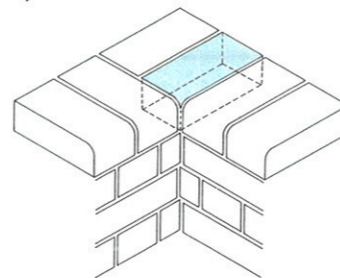
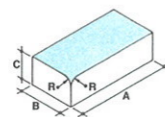

**BN.10 (2.3.10)** Bullnose external return on edge (left and right hand)  
Associated special brick: BN.1 (2.3.1)



TYPE	A	B	C	R
BN.10.1	215	65	103	25
BN.10.2	215	65	103	51
BN.10.3	215	215	103	25
BN.10.4	215	215	103	51

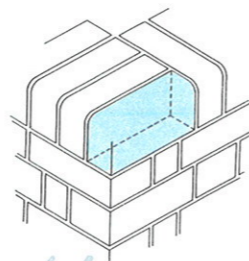
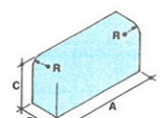

*www.Brickworld.NL*

**GROUP BN BULLNOSE BRICKS**

**BN.11 (2.3.11)** Bullnose external return on flat (left and right hand)  
Associated special bricks: BN.5 (2.3.5), BN.6 (2.3.6)

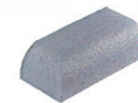

TYPE	A	B	C	R
BN.11.1	215	103	65	25
BN.11.2	215	103	65	51
BN.11.3	215	215	65	25
BN.11.4	215	215	65	51

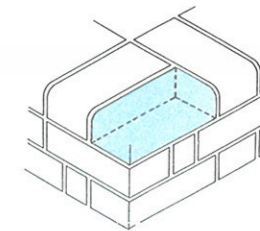
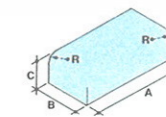

**BN.12 (2.3.12)** Bullnose mitre (left and right hand)  
Associated special bricks: BN.1 (2.3.1), BN.5 (2.3.5), BN.6 (2.3.6)



TYPE	A	B	C	R
BN.12.1	215	103	65	25
BN.12.2	215	103	65	51

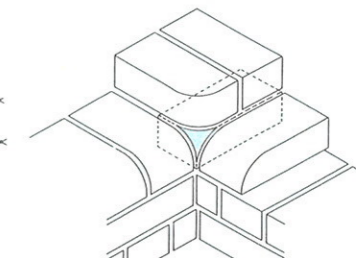
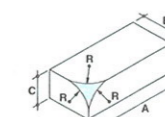

**BN.13 (2.3.13)** Bullnose double header on flat



TYPE	A	B	C	R
BN.13.1	215	103	65	25
BN.13.2	215	103	65	51

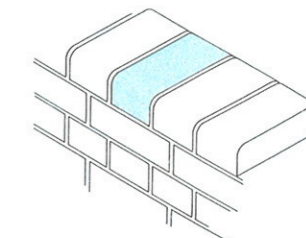
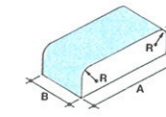

**BN.14 (2.3.14)** Bullnose double stretcher on flat



TYPE	A	B	C	R
BN.14.1	215	103	65	25
BN.14.2	215	103	65	51

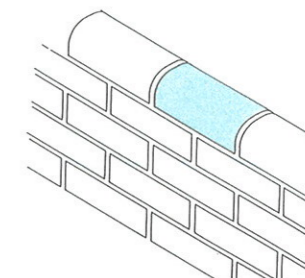
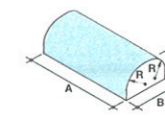

**BN.15 (2.3.15)** Stop end to double bullnose on edge and to bullnose double header on flat  
(square corners on bed)  
Associated special bricks: BN.2 (2.3.2), BN.13 (2.3.13)

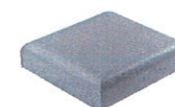

TYPE	A	B	C	R
BN.15.1	215	159	103	25
BN.15.2	215	159	103	51
BN.15.3	215	215	103	25
BN.15.4	215	215	103	51
BN.15.5	215	159	65	25
BN.15.6	215	159	65	51
BN.15.7	215	215	65	25
BN.15.8	215	215	65	51

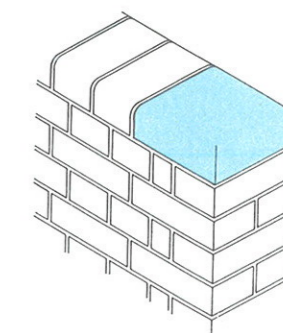

## GROUP CP COPINGS AND CAPPINGS

Typical uses are as a decorative finish to parapet walls and free-standing walls and to protect the brickwork beneath.

**Note:** All copings and cappings must be FL quality to BS 3921:1985.

It is recommended that cappings are used in conjunction only with FL quality brickwork.

Copings always overhang the brickwork beneath; cappings are flush with the vertical brickwork. It is also recommended that careful consideration is given to the detailing below both copings and cappings.

### CP.1.1 (2.2.1) Half round coping



TYPE	A	B	C	D <sub>1</sub>	D <sub>2</sub>
CP.1.1	305	153	65	13	15

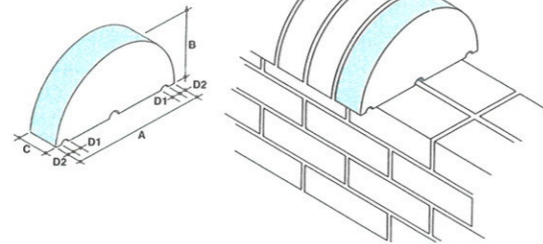

### CP.1.2 Half round capping



TYPE	A	B	C
CP.1.2	215	108	65

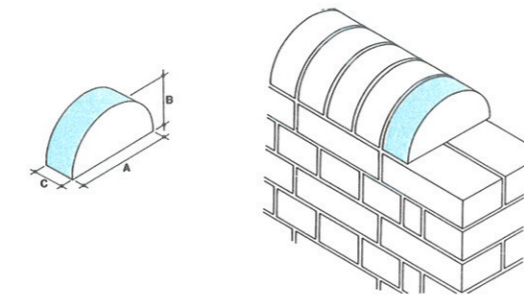

### CP.2.1 (2.2.2) Saddleback coping



TYPE	A	B	C	D <sub>1</sub>	D <sub>2</sub>	E
CP.2.1	305	153	65	13	15	50

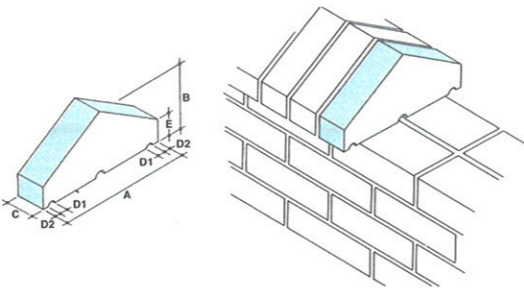

### CP.2.2 Saddleback capping

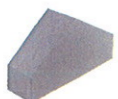

TYPE	A	B	C	E
CP.2.2	215	123	65	50

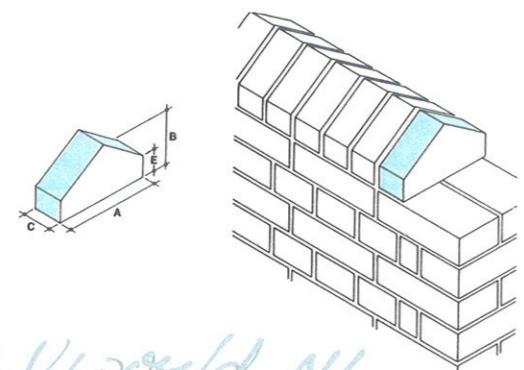

www.Brickworld.nl

## GROUP BN BULLNOSE BRICKS

Typically used for feature brickwork where a radius is required, for example, corner details, window/door reveals, pier work. Can also act as capping (see Group CP) or for edging kerbs. This group also includes special bricks to provide an aesthetic visual transition between square and curved elements.

### BN.1 (2.3.1) Single bullnose (left and right hand)



TYPE	A	B	C	R
BN.1.1	215	103	65	25
BN.1.2	215	103	65	51

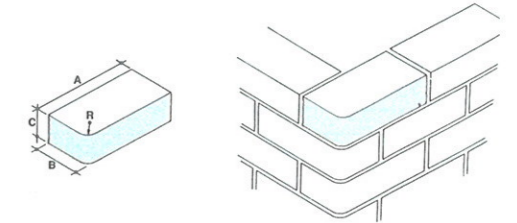

### BN.2 (2.3.2) Double bullnose



TYPE	A	B	C	R
BN.2.1	215	103	65	25
BN.2.2	215	103	65	51

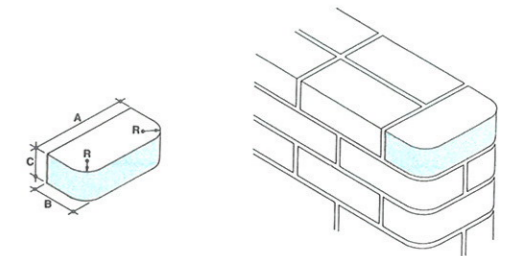

### BN.3 (2.3.3) Single bullnose stop (left and right hand) Associated special brick: BN.1 (2.3.1)



TYPE	A	B	C	D	R
BN.3.1	215	103	65	25	25
BN.3.2	215	103	65	25	51

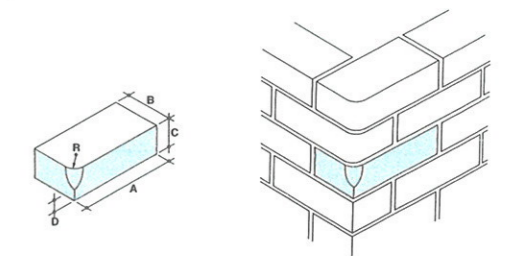

### BN.4 (2.3.4) Double bullnose stop Associated special bricks: BN.1 (2.3.1), BN.2 (2.3.2)



TYPE	A	B	C	D	R
BN.4.1	215	103	65	25	25
BN.4.2	215	103	65	25	51

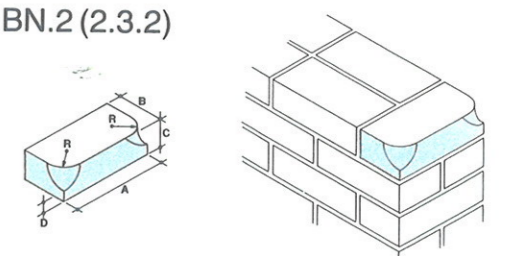

### BN.5 (2.3.5) Single bullnose header on flat

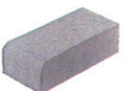

TYPE	A	B	C	R
BN.5.1	215	103	65	25
BN.5.2	215	103	65	51

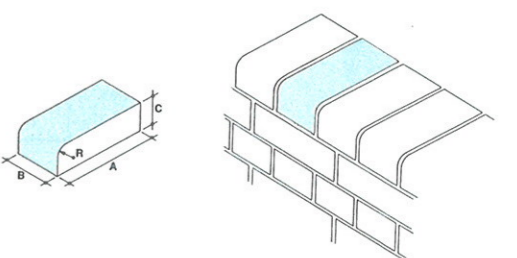

**GROUP BN BULLNOSE BRICKS**

**BN.16 (2.3.16) Cownose**



TYPE	A	B	C	R
BN.16.1	215	103	65	25
BN.16.2	215	103	65	51

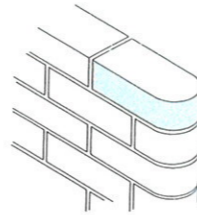
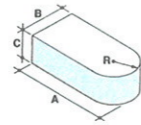

**BN.17 (2.3.17) Cownose stop**  
Associated special brick: BN.16 (2.3.16)



TYPE	A	B	C	D	R
BN.17.1	215	103	65	25	25
BN.17.2	215	103	65	25	51

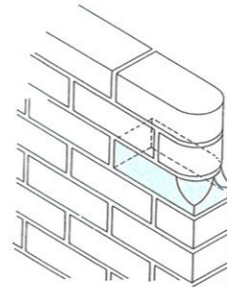
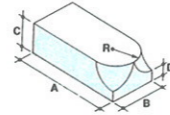

**BN.18**  
Stop end to double bullnose on edge and to bullnose double header on flat (rounded corners on bed)  
Associated special bricks: BN.1 (2.3.1), BN.2 (2.3.2), BN.13 (2.3.13)



TYPE	A	B	C	R
BN.18.1	215	159	103	25
BN.18.2	215	159	103	51
BN.18.3	215	215	103	25
BN.18.4	215	215	103	51
BN.18.5	215	159	65	25
BN.18.6	215	159	65	51
BN.18.7	215	215	65	25
BN.18.8	215	215	65	51

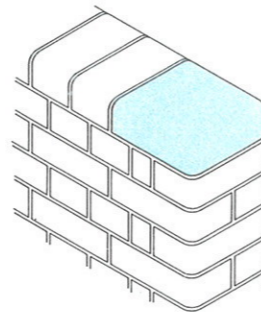
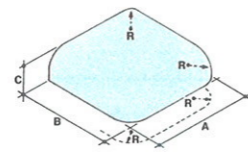

**BN.19**  
External return to double bullnose on edge and to bullnose double header on flat (square corners on bed)  
Associated special bricks: BN.2 (2.3.2), BN.13 (2.3.13)



TYPE	A	B	C	R
BN.19.1	215	215	103	25
BN.19.2	215	215	103	51
BN.19.3	215	215	65	25
BN.19.4	215	215	65	51

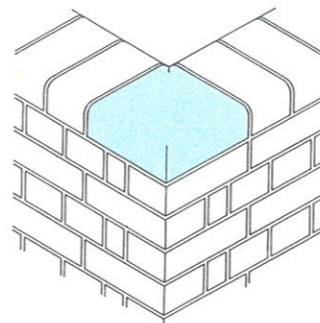
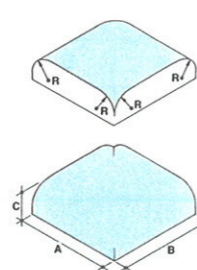

*www.Brickworld.nl*

**GROUP BN BULLNOSE BRICKS**

**BN.20**  
External return to double bullnose on edge and to bullnose double header on flat (rounded corners on bed)  
Associated special bricks: BN.1 (2.3.1), BN.2(2.3.2), BN.13 (2.3.13)



TYPE	A	B	C	R
BN.20.1	215	215	103	25
BN.20.2	215	215	103	51
BN.20.3	215	215	65	25
BN.20.4	215	215	65	51

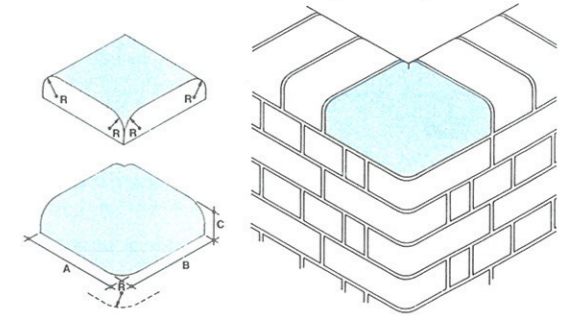

**BN.21**  
Double bullnose external return to double bullnose on edge and to bullnose double header on flat  
Associated special bricks: BN.2 (2.3.2), BN.13 (2.3.13), AN.1 (2.4.1), AN.2 (2.4.2), AN.3 (2.4.3)



TYPE	A	B	C	D	R	α
BN.21.1	215	103	159	101	25	30°
BN.21.2	215	103	159	101	51	30°
BN.21.3	215	65	159	101	25	30°
BN.21.4	215	65	159	101	51	30°
BN.21.5	215	103	159	70	25	45°
BN.21.6	215	103	159	70	51	45°
BN.21.7	215	65	159	70	25	45°
BN.21.8	215	65	159	70	51	45°
BN.21.9	215	103	159	35	25	60°
BN.21.10	215	103	159	35	51	60°
BN.21.11	215	65	159	35	25	60°
BN.21.12	215	65	159	35	51	60°

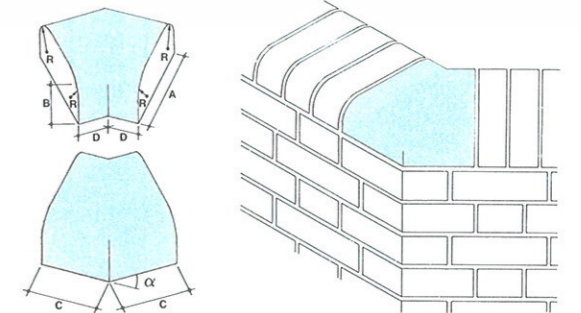

**GROUP AN ANGLE AND CANT BRICKS**

Angle bricks generally serve a functional purpose where it is necessary to carry a building element through an angle other than 90°. Cant bricks are typically used for feature brickwork where crisp, clean lines are required e.g. corner details, window/door reveals, pier work. They can also be used for capping (see Group CP).

**AN.1 (2.4.1) Squint (left or right hand)**



TYPE	A	B	C	D	E	α
AN.1.1	164	103	65	51	89	30°
AN.1.2	164	103	65	51	95	45°
AN.1.3	164	103	65	51	118	60°

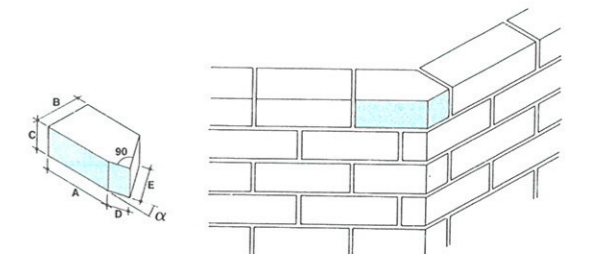

**GROUP AN**

**ANGLE AND CANT BRICKS**

**AN.2 (2.4.2)**

External angle (left or right hand)



TYPE	A	B	C	D	$\alpha$
AN.2.1	159	103	65	103	30°*
AN.2.2	159	103	65	103	45°*
AN.2.3	159	103	65	103	60°*
AN.2.4	215	103	65	103	30°†
AN.2.5	215	103	65	103	45°†
AN.2.6	215	103	65	103	60°†

**NOTE:** Some types of bricks may not be available with A=215.

\*Suitable for quarter bond without cutting.

†Suitable for half bond without cutting.

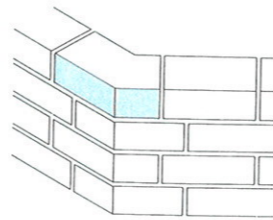
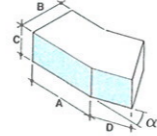

**AN.3 (2.4.3)**

Internal angle (dog leg) (left or right hand)



TYPE	A	B	C	D	$\alpha$
AN.3.1	164	103	65	51	30°†
AN.3.2	164	103	65	51	45°†
AN.3.3	164	103	65	51	60°†
AN.3.4	159	103	65	103	30°*
AN.3.5	159	103	65	103	45°*
AN.3.6	159	103	65	103	60°*
AN.3.7	215	103	65	103	30°†
AN.3.8	215	103	65	103	45°†
AN.3.9	215	103	65	103	60°†

**NOTE:** Some types of bricks may not be available with A=215.

\*Suitable for quarter bond without cutting.

†Suitable for half bond without cutting.

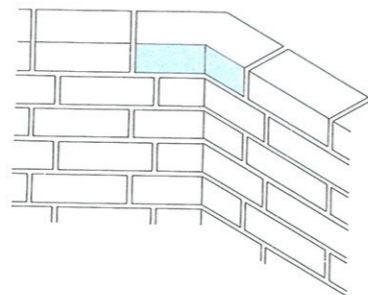
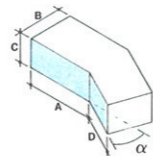

**AN.4 (2.4.4)**

Birdsmouth



TYPE	A	B	C	$\alpha$
AN.4.1	215	103	65	120°
AN.4.2	215	103	65	135°
AN.4.3	215	103	65	150°

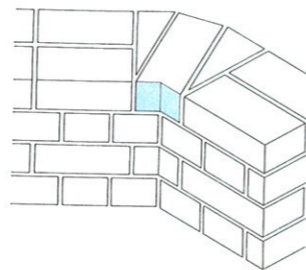
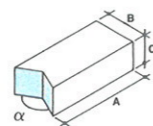

**AN.5 (2.4.5)**

Single cant (left or right hand)



TYPE	A	B	C	D	E
AN.5.1	215	103	65	46	159
AN.5.2	215	103	65	60	172

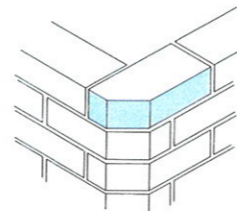
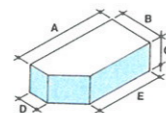

**AN.6 (2.4.6)**

Double cant



TYPE	A	B	C	D	E
AN.6.1	215	103	65	46	103
AN.6.2	215	103	65	60	129

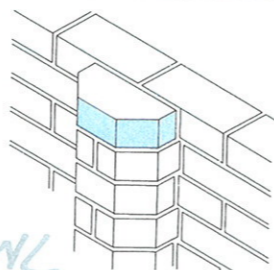
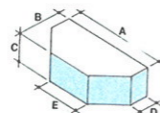

*www.Brickworld.nl*

**GROUP AN**

**ANGLE AND CANT BRICKS**

**AN.7 (2.4.7)**

Single cant return

Associated special brick: AN.5 (2.4.5)

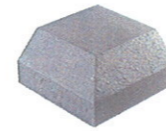

TYPE	A	B	C	D	E
AN.7.1	215	215	103	46	159
AN.7.2	215	215	103	60	172

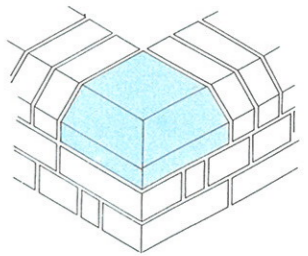
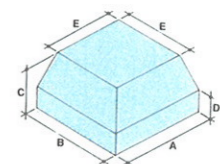

**AN.8**

Single cant internal return with internal mitre (square external corner on bed)

Associated special brick: AN.5 (2.4.5)



TYPE	A	B	C	D	E
AN.8.1	215	215	103	46	159
AN.8.2	215	215	103	60	172

**NOTE:** Faced on 2 full stretchers.

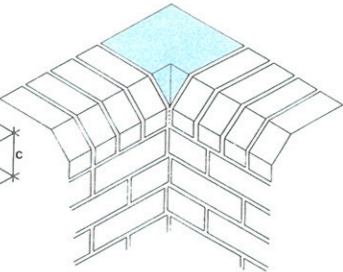
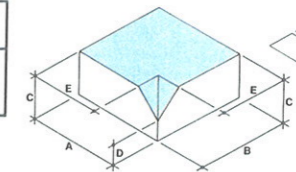

**AN.9**

Single cant internal return with internal slope (square external corner on bed)

Associated special brick: AN.5 (2.4.5)

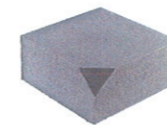

TYPE	A	B	C	D	E
AN.9.1	215	215	103	46	159
AN.9.2	215	215	103	60	172

**NOTE:** Faced on 2 full stretchers.

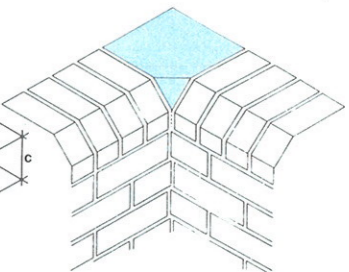
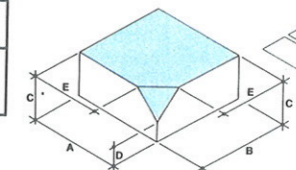

**AN.10**

Single cant external angle

Associated special bricks: AN.2 (2.4.2), AN.5 (2.4.5)



TYPE	A	B	C	D	E	F	$\alpha$
AN.10.1	215	103	159	46	159	101	30°
AN.10.2	215	103	159	60	172	101	30°
AN.10.3	215	103	159	46	159	70	45°
AN.10.4	215	103	159	60	172	70	45°
AN.10.5	215	103	159	46	159	35	60°
AN.10.6	215	103	159	60	172	35	60°

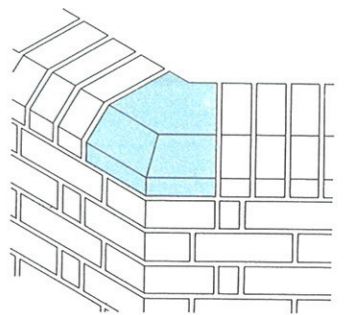
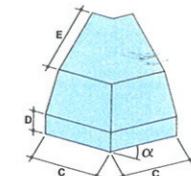
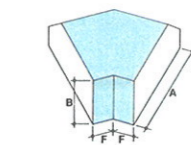

**AN.11**

Single cant internal angle

Associated special bricks: AN.3 (2.4.3), AN.5 (2.4.5)

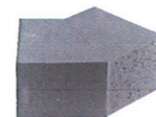

TYPE	A	B	C	D	E	F	$\alpha$
AN.11.1	215	103	159	46	159	101	30°
AN.11.2	215	103	159	60	172	101	30°
AN.11.3	215	103	159	46	159	70	45°
AN.11.4	215	103	159	60	172	70	45°
AN.11.5	215	103	159	46	159	35	60°
AN.11.6	215	103	159	60	172	35	60°

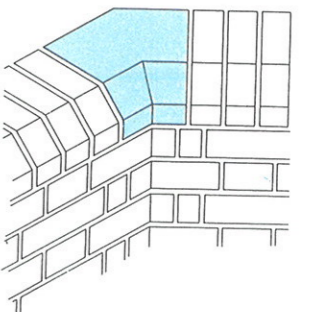
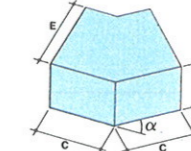
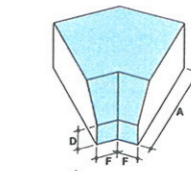

**GROUP AN ANGLE AND CANT BRICKS**

**AN.12**

Double cant stop end (square corners on bed)  
Associated special brick: AN.6 (2.4.6)



TYPE	A	B	C	D	E	F
AN.12.1	215	215	103	46	103	159
AN.12.2	215	215	103	60	129	172

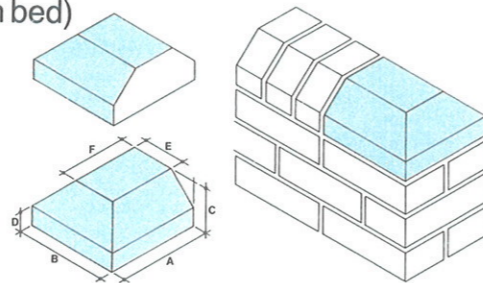

**AN.13**

Double cant stop end (canted corners)  
Associated special bricks: AN.5 (2.4.5), AN.6 (2.4.6)



TYPE	A	B	C	D	E	F
AN.13.1	215	215	103	46	103	159
AN.13.2	215	215	103	60	129	172

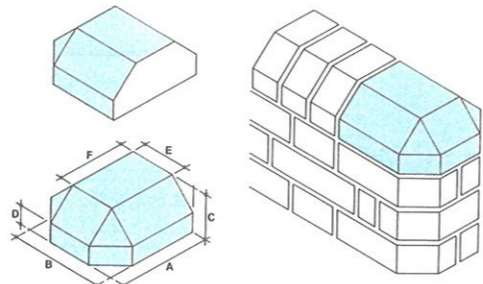

**AN.14**

Double cant external return with internal mitre (square corners on bed)  
Associated special brick: AN.6 (2.4.6)



TYPE	A	B	C	D	E
AN.14.1	215	215	103	46	103
AN.14.2	215	215	103	60	129

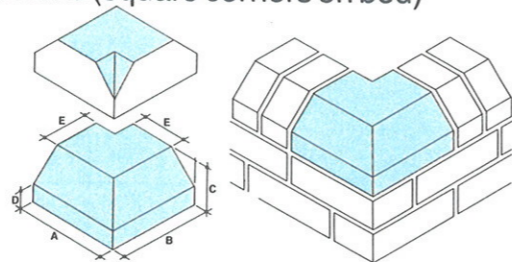

**AN.15**

Double cant external return with internal mitre (canted corners on bed)  
Associated special bricks: AN.5 (2.4.5), AN.6 (2.4.6)



TYPE	A	B	C	D	E	F
AN.15.1	215	215	103	46	103	159
AN.15.2	215	215	103	60	129	172

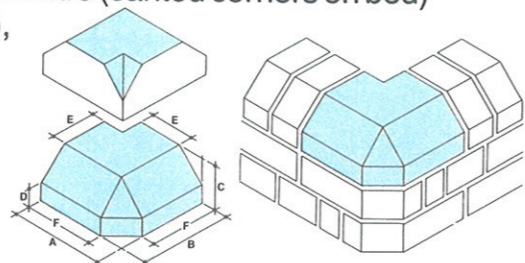

**AN.16**

Double cant external return with internal slope (square corners on bed)  
Associated special brick: AN.6 (2.4.6)



TYPE	A	B	C	D	E
AN.16.1	215	215	103	46	103
AN.16.2	215	215	103	60	129

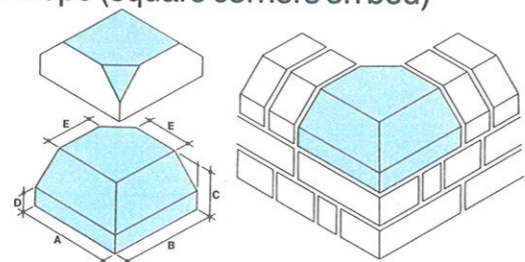

**AN.17**

Double cant external return with internal slope (canted corners on bed)  
Associated special bricks: AN.5 (2.4.5), AN.6 (2.4.6)



TYPE	A	B	C	D	E	F
AN.17.1	215	215	103	46	103	159
AN.17.2	215	215	103	60	129	172

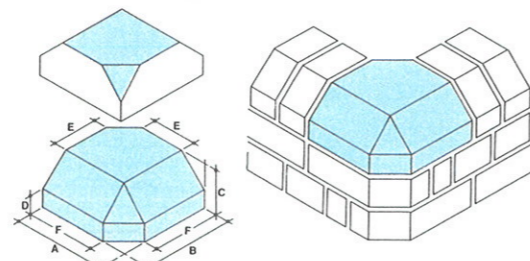

**GROUP AN ANGLE AND CANT BRICKS**

**AN.18**

Double cant angle  
Associated special bricks: AN.2 (2.4.2.), AN.3 (2.4.3), AN.6 (2.4.6)

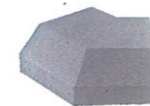

TYPE	A	B	C	D	E	F	$\alpha$
AN.18.1	215	103	159	46	103	101	30°
AN.18.2	215	103	159	60	129	101	30°
AN.18.3	215	103	159	46	103	70	45°
AN.18.4	215	103	159	60	129	70	45°
AN.18.5	215	103	159	46	103	35	60°
AN.18.6	215	103	159	60	129	35	60°

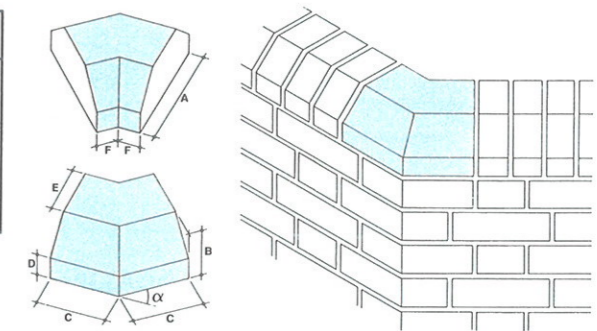

**GROUP PL PLINTH BRICKS**

Typically used for aesthetic detailing where hard lines are required e.g. returns, window cills, corbelling details, kerbs and capping (see Group CP).

**PL.1 (2.5.1)**

Plinth stop or cant stop (left or right hand)  
Associated special bricks: PL.2 (2.5.2), PL.3 (2.5.3), AN.5 (2.4.5)



TYPE	A	B	C	D	E	F	$\theta$
PL.1.1	215	103	65	8	159	46	45°
PL.1.2	215	103	65	22	172	60	45°

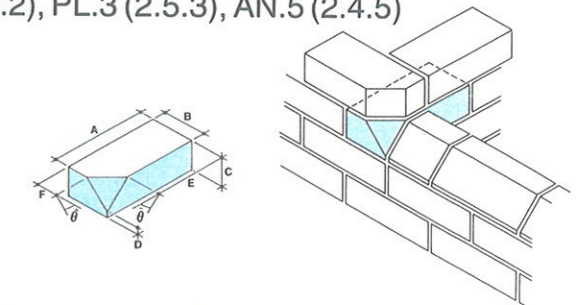

**PL.2 (2.5.2)**

Plinth header



TYPE	A	B	C	D	E	$\theta$
PL.2.1	215	103	65	8	159	45°
PL.2.2	215	103	65	22	172	45°

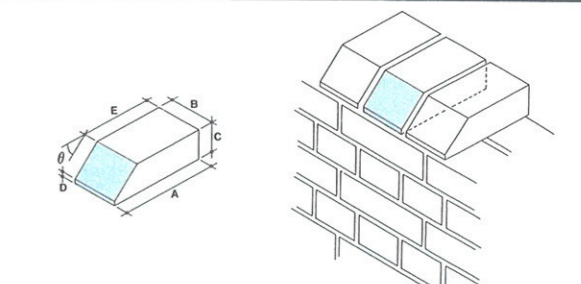

**PL.3 (2.5.3)**

Plinth stretcher



TYPE	A	B	C	D	E	$\theta$
PL.3.1	215	103	65	8	46	45°
PL.3.2	215	103	65	22	60	45°

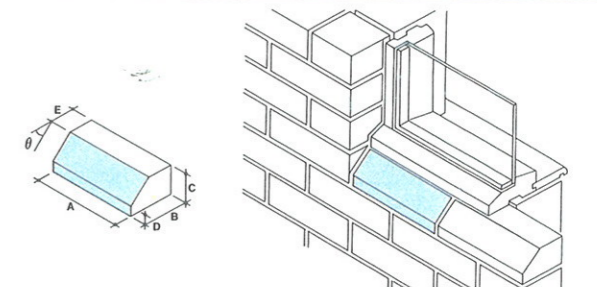

**PL.4 (2.5.4)**

Plinth internal return (long) (left or right hand)  
Associated special brick: PL.3 (2.5.3)



TYPE	A	B	C	D	E	F	$\theta$
PL.4.1	215	103	65	8	46	169	45°
PL.4.2	215	103	65	22	60	155	45°

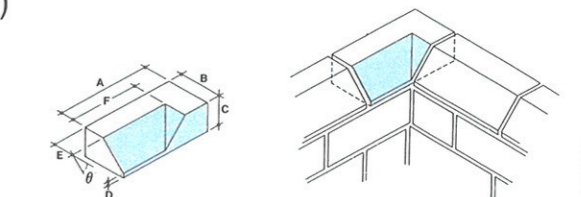

*www.Brickworld.nl*

## GROUP PL PLINTH BRICKS

### PL.5 (2.5.5)

Plinth internal return (short) (left or right hand)  
Associated special bricks: PL.2 (2.5.2), PL.3 (2.5.3)



TYPE	A	B	C	D	E	F	$\theta$
PL.5.1	215	103	65	8	159	46	45°
PL.5.2	215	103	65	22	172	60	45°

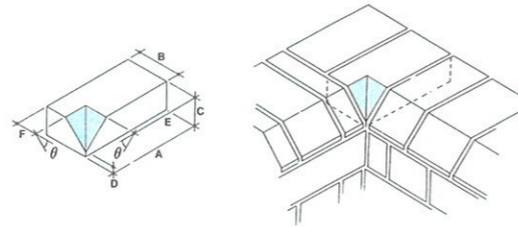

### PL.6 (2.5.6)

Plinth internal angle (left or right hand)  
Associated special bricks: PL.3 (2.5.3), AN.3 (2.4.3)



TYPE	A	B	C	D	E	F	$\alpha$	$\theta$
PL.6.1	164	103	65	8	51	46	30°†	45°
PL.6.2	164	103	65	22	51	60	30°†	45°
PL.6.3	164	103	65	8	51	46	45°†	45°
PL.6.4	164	103	65	22	51	60	45°†	45°
PL.6.5	164	103	65	8	51	46	60°†	45°
PL.6.6	164	103	65	22	51	60	60°†	45°
PL.6.7	159	103	65	8	103	46	30°*	45°
PL.6.8	159	103	65	22	103	60	30°*	45°
PL.6.9	159	103	65	8	103	46	45°*	45°
PL.6.10	159	103	65	22	103	60	45°*	45°
PL.6.11	159	103	65	8	103	46	60°*	45°
PL.6.12	159	103	65	22	103	60	60°*	45°
PL.6.13	215	103	65	8	103	46	30°†	45°
PL.6.14	215	103	65	22	103	60	30°†	45°
PL.6.15	215	103	65	8	103	46	45°†	45°
PL.6.16	215	103	65	22	103	60	45°†	45°
PL.6.17	215	103	65	8	103	46	60°†	45°
PL.6.18	215	103	65	22	103	60	60°†	45°

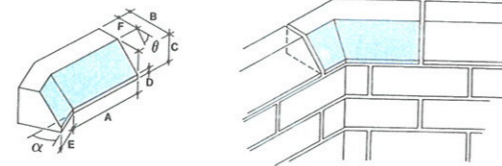

NOTE: Some types of bricks may not be available with A=215.

\*Suitable for quarter bond without cutting.

†Suitable for half bond without cutting.

### PL.7 (2.5.7)

Plinth external return (left or right hand)  
Associated special brick: PL.3 (2.5.3)

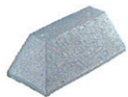

TYPE	A	B	C	D	E	F	$\theta$
PL.7.1	215	103	65	8	158	46	45°
PL.7.2	215	103	65	22	172	60	45°

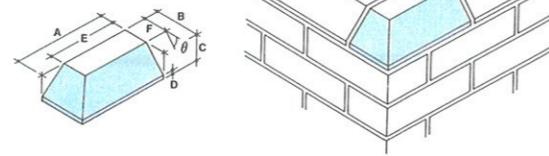

### PL.8 (2.5.8)

Plinth external angle (left or right hand)  
Associated special bricks: PL.3 (2.5.3), AN.2 (2.4.2)



TYPE	A	B	C	D	E	F	$\alpha$	$\theta$
PL.8.1	159	103	65	8	103	46	30°	45°
PL.8.2	159	103	65	22	103	60	30°	45°
PL.8.3	159	103	65	8	103	46	45°	45°
PL.8.4	159	103	65	22	103	60	45°	45°
PL.8.5	159	103	65	8	103	46	60°	45°
PL.8.6	159	103	65	22	103	60	60°	45°
PL.8.7	215	103	65	8	103	46	30°	45°
PL.8.8	215	103	65	22	103	60	30°	45°
PL.8.9	215	103	65	8	103	46	45°	45°
PL.8.10	215	103	65	22	103	60	45°	45°
PL.8.11	215	103	65	8	103	46	60°	45°
PL.8.12	215	103	65	22	103	60	60°	45°

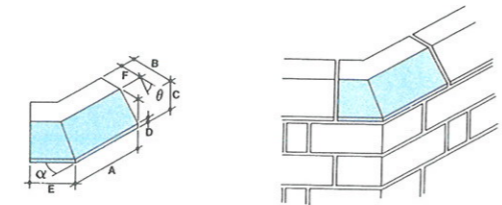

NOTE: Some types of bricks may not be available with A=215.

## GROUP PL PLINTH BRICKS

### PL.9

Plinth squint (left or right hand)  
Associated special bricks: PL.3 (2.5.3), AN.1 (2.4.1)



TYPE	A	B	C	D	E	F	$\alpha$	$\theta$
PL.9.1	164	103	65	8	51	46	30°	45°
PL.9.2	164	103	65	22	51	60	30°	45°
PL.9.3	164	103	65	8	51	46	45°	45°
PL.9.4	164	103	65	22	51	60	45°	45°
PL.9.5	164	103	65	8	51	46	60°	45°
PL.9.6	164	103	65	22	51	60	60°	45°

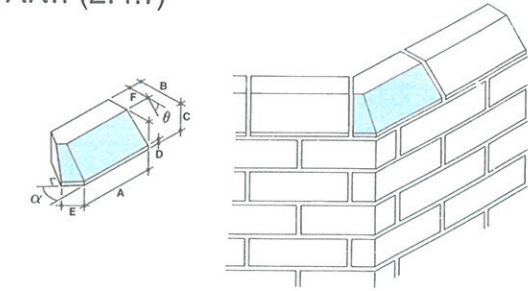

## GROUP AR ARCH BRICKS

Typically used to provide structural stability in curved elements such as arches or for aesthetic detailing e.g. circular windows.

### AR.1 (2.6.1)

Tapered header

TYPE	UNIT DIMENSIONS				IDEAL SPAN* DIMENSIONS		NO. OF WHOLE BRICKS	NO. OF BRICKS† IN SEMI-CIRCLE
	A	B	C	D				
AR.1.1	215	103	75	59	910mm	4	20 or 21	
AR.1.2	215	103	75	64	1360mm	6	28 or 29	
AR.1.3	215	103	75	66	1810mm	8	36 or 37	
AR.1.4	215	103	75	69	2710mm	12	53 or 54	



\*It is possible to use standard arch bricks for spans other than the 'ideal', ranging from 800mm to 3000mm in half-brick increments, by varying the number of bricks, providing the slight tapering of the joints is aesthetically acceptable. The taper may vary between 0.9mm and 1.6mm for the smallest span to less than 1mm for the larger spans.

†Parallel joints of acceptable width are achieved using either of the alternative number of bricks in the semi-circle if the bricks conform to the work sizes.

The actual size of bricks normally varies slightly from the work size. If the bricks on site are larger, then the smaller number of bricks in the semi-circle would be more appropriate and vice versa.

NOTE: Faced on 2 headers.

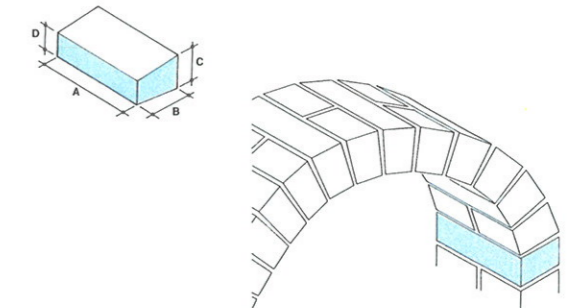

### AR.2 (2.6.2)

Tapered stretcher

TYPE	UNIT DIMENSIONS				IDEAL SPAN* DIMENSIONS		NO. OF WHOLE BRICKS	NO. OF BRICKS† IN SEMI-CIRCLE
	A	B	C	D				
AR.2.1	215	103	75	48	910mm	4	24 or 25	
AR.2.2	215	103	75	55	1360mm	6	33 or 34	
AR.2.3	215	103	75	58	1810mm	8	41 or 42	
AR.2.4	215	103	75	63	2710mm	12	58 or 59	



\*This format is not as versatile in application as the AR.1 series because the longer voussoir joint accentuates spalls. Tolerance allowances limit versatility further.

†Parallel joints of acceptable width are achieved using either of the alternative number of bricks in the semi-circle if the bricks conform to the work sizes.

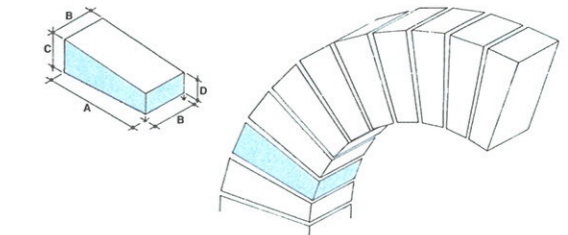

www.Brickworld.nc

## GROUP RD RADIAL BRICKS

As a functional brick, typically used for structures such as industrial chimneys. Also particularly effective used as an aesthetic device producing a sweeping "curved" effect.

### RD.1 (2.7.1) Radial header

TYPE	A	*B	C	*D	IDEAL RADIUS		NO. OF BRICKS IN QUADRANT
					OUTER	INNER	
RD.1.1	215	108	65	52	450	235	6
RD.1.2	215	108	65	70	675	460	9
RD.1.3	215	108	65	80	900	685	12
RD.1.4	215	108	65	89	1350	1135	18
RD.1.5	215	108	65	97	2250	2035	30
RD.1.6	215	108	65	103	5400	5185	72

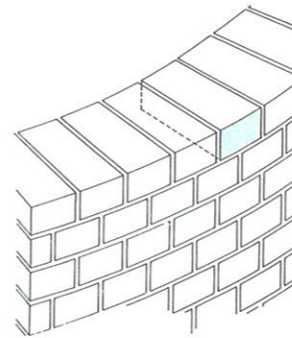
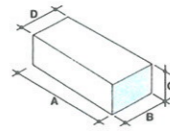

\*Dimensions B and D in types RD.1 are segmental lengths.  
NOTE: Faced on 2 headers.

### RD.2 (2.7.2) Radial stretcher

TYPE	*A	B	C	*D	IDEAL RADIUS		NO. OF BRICKS IN QUADRANT
					OUTER	INNER	
RD.2.1	226	103	65	172	450	347	3
RD.2.2	226	103	65	190	675	572	4½
RD.2.3	226	103	65	199	900	797	6
RD.2.4	226	103	65	208	1350	1247	9
RD.2.5	226	103	65	215	2250	2147	15
RD.2.6	226	103	65	221	5400	5297	36

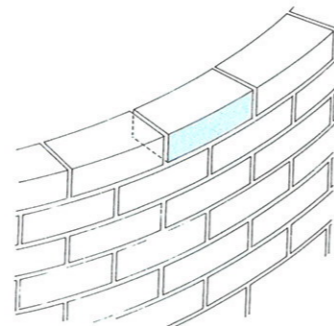
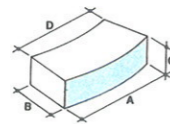

\*Dimensions A and D in types RD.2 are segmental lengths.  
NOTE: Faced on 2 stretchers

## GROUP SL BRICK SLIPS

Typically used to mask reinforced concrete frames and for interior work.

### SL.1 (2.8.1) Brick face slip

TYPE	A	B	C
SL.1.1	215	25	65
SL.1.2	215	30	65
SL.1.3	215	40	65
SL.1.4	215	50	65

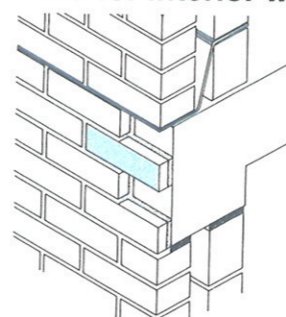
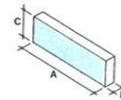

## GROUP SL BRICK SLIPS

### SL.2 (2.8.2) Brick bed slip

TYPE	A	B	C
SL.2	215	103	25

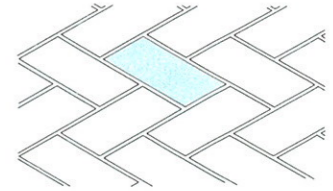
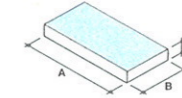

## GROUP SD SOLDIER BRICKS

Typically used as an aesthetic means of returning a soldier course detail.

### SD.1 Soldier return

TYPE	A	B	C
SD.1.1	215	65	65
SD.1.2	215	103	103

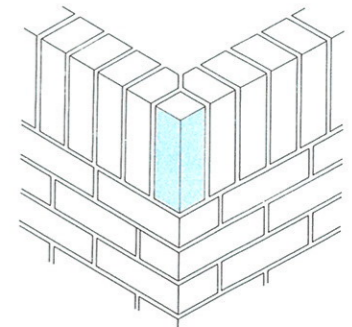
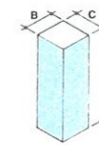

### SD.2 Internal return to single cant on end

TYPE	A	B	C	D	E
SD.2.1	215	103	103	46	159
SD.2.2	215	103	103	60	172

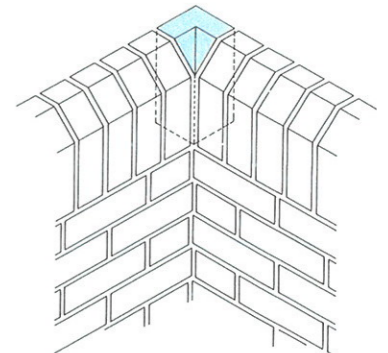
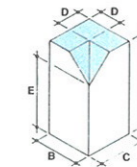

### SD.3 External return to single cant on end

TYPE	A	B	C	D	E
SD.3.1	215	103	103	46	159
SD.3.2	215	103	103	60	172

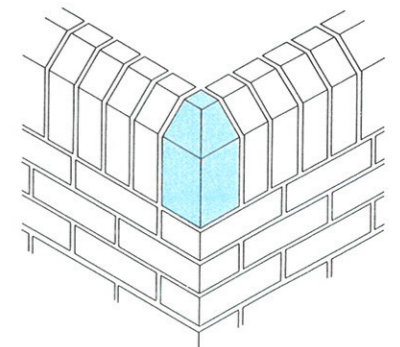
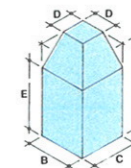

www.Brickworld.com